



Specification sheet

Fire pump drive engine

CFP30E-F20
CFP30EVS-F20



Description

Engine series - Cummins QST30 Series

The CFP30E has higher torque, shorter service times, longer maintenance intervals, and increased fuel economy. Customers request this model due to the durability and compactness of the design which can be configured to meet most applications.

Features

Variable Speed Pressure Limiting Control (VSPLC) - Cummins' VSPLC-equipped fire pump drive engines are capable of maintaining a constant pump discharge pressure by controlling the engine speed down to 1400 RPM. VSPLC fire pump drive engines provide design flexibility in the fire pump system for high-rise applications; allow the system architect to apply a larger pump and/or a pump with a steeper curve; and significantly reduce water consumption during the weekly test.

Certified power - Many of the CFP30E-F20 ratings comply with NFPA 20 and are UL 1247 Listed and FM 1333 Approved. See the ratings table below.

Control system - The industry-leading, state-of-the-art Fire Pump Digital Panel (FPDP) provides total fire pump drive engine system integration and intuitive operation, including:

- Color touchscreen;
- Dual microprocessors for critical signal redundancy;
- Standard J1939 parameter and Cummins fault code display;
- Engine idling;
- Electronic Control Module (ECM) self-diagnosis; and
- Optional Modbus field server remote messaging capability.

Warranty and service - Our models are backed by a comprehensive warranty and worldwide distributor network.

Ratings in HP (kW) and certifications

Operating speed (RPM)	1470		1760		1900		2100	
	CFP30E-F20	1017	(759)	1137	(848)	1115	(832)	997
	NFPA, only		NFPA, UL & FM		NFPA, UL & FM		NFPA, UL & FM	
Operating speed (RPM)	1470		1760		1900		2100	
	CFP30EVS-F20	N/A	1137	(848)	1115	(832)	997	(744)
			NFPA & FM		NFPA & FM		NFPA & FM	

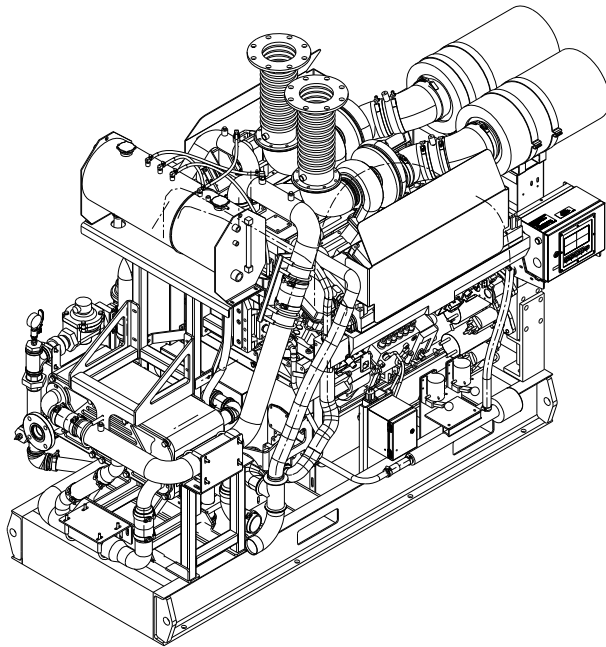

General engine data

Engine type	4 Cycle; In-Line, 12 Cylinder
Aspiration	Turbocharged/ 2 Pump - 2 Loop After-cooled
Bore and stroke	5.51 x 6.50 in. (140 x 165 mm)
Displacement	1860 in ³ (30.5 L)
Rotation	Counter-clockwise from flywheel end
Compression ratio	14.0:1
Valves per cylinder	Intake - 2 Exhaust - 2
Fuel system	Bosch Electronic
Maximum allowable bending moment @ rear face of block	2286 lb.-ft. (3099 N-m)
Estimated wet weight*	10,325 lbs. (4683 kg)

* Weight includes engine, cooling loop, heat exchanger, dual Electronic Control Modules (ECMs), Fire Pump Digital Panel (FPDP), standard air cleaner, standard exhaust flex, and all fluids.

Equipment	Standard	Optional
Air cleaner	Direct-mounted, disposable indoor service	N/A
Alternator	24V-DC, 75 amps; includes belt guard	N/A
Cooling loop (maximum pressure of 300 PSI)	2" diameter for fresh water; includes alarm sensors	Cu Ni construction available for sea water applications
Cooling system	40 PSI with flange connections, plate type	N/A
Engine heater	(2) 240V-AC, 4000 watts	(2) 480V-AC, 4000 watts
Exhaust protection	Metal guards on manifolds and turbocharger	N/A
Exhaust flex connection	Steel, flanged	Stainless steel flex, NPT
Flywheel power take-off	Flywheel	Driveshaft system
Fuel connections	Fire-resistant flexible supply and return lines	N/A
Fuel filter	Spin-on primary and secondary	N/A
Governor, speed	Constant speed, electronic	VSPLC ¹
Fire pump digital panel (FPDP)	7" color touchscreen; enclosure rated as Type 2/Type 4X; Imperial and metric values	Optional 316SS construction; custom gauges with digital panel expansion module (DPEM)
Lube oil cooler	Engine-water-cooled, plate type	N/A
Lube oil filter	Full-flow with by-pass valve	N/A
Lube oil pump	Gear-driven	N/A
Manual start controls	On FPDP and/or contactors	N/A
Overspeed controls	Electronic with reset and test on FPDP	N/A
Starter	24V-DC	24V-DC/pneumatic ² /hydraulic ²

¹ FM Approved, but not UL Listed.

² Only approved as a secondary starter.

Air induction system

Maximum temperature rise between ambient air and engine air inlet	30 °F (16.7 °C)
Maximum inlet restriction with dirty filter	18 in. H ₂ O (457 mm H ₂ O)
Recommended air cleaner element - (standard)	(2) Cummins Filtration AH19076

Lubrication system

Oil pressure range at rated	48-55 PSI (331-379 kPa)
Oil capacity of pan (high - low)	80-60 qt. (76-57 L)
Total system capacity	26 gal. (98 L)
Recommended lube oil filter	(4) Cummins Filtration LF9001

Cooling system*

Raw water working pressure range at heat exchanger	40 PSI (276 kPa) MAX
Recommended minimum water supply pipe size to heat exchanger	2 in. (50.80 mm)
Recommended minimum water discharge pipe size from heat exchanger	2.50 in. (63.50 mm)
Coolant total system capacity	55 gal. (208.2 L)
Standard thermostat - type	Modulating
Standard thermostat - range	170-194 °F (76.5-90 °C)
Normal Operating Temperature	180-212 °F (82-100 °C)
Minimum raw water flow:	
- with water temperatures to 60 °F (16 °C)	134 GPM (8.45 L/sec)
- with water temperatures to 80 °F (27 °C)	168 GPM (10.60 L/sec)
- with water temperatures to 100 °F (38 °C)	206 GPM (13 L/sec)
Recommended cooling water filter	(2) Cummins Filtration WF2075

* A jacket water heater is mandatory on this engine. The recommended heater wattage for the two heaters is 4000 down to 40 °F (4 °C)

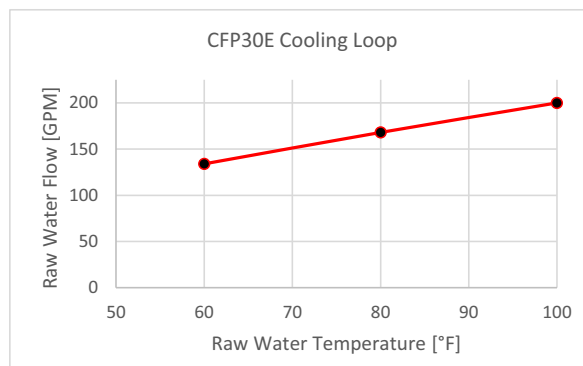

Exhaust system

Maximum allowable back pressure by complete exhaust system	40.8 in. H ₂ O (10.2 kPa)
Exhaust pipe size normally acceptable	10 in. (254 mm)

Noise emissions - The noise emission values are estimated sound pressure levels at 3.3 ft. (1 m).

Top	106 dBa
Right side	106 dBa
Left side	106 dBa
Front	106 dBa
Exhaust	120 dBa

Fuel supply/drain system

Operating speed in RPM	1470		1760		1900		2100	
	Fuel rate - gal/hr (L/hr)							
	47.1	(178)	54.9	(208)	54.9	(208)	50.3	(190)
Fuel type	No. 2 diesel only							
Minimum supply line size	1 in. (25.40 mm)							
Minimum drain line size	1 in. (25.40 mm)							
Maximum fuel line length between supply tank and fuel pump	40 ft. (12 m)							
Maximum fuel inlet pressure	25 PSI (172 kPa)							
Recommended fuel filter - primary	(1) Cummins Filtration FF2203							
Recommended fuel filter - secondary	(1) Cummins Filtration FS1006							
Maximum restriction @ lift pump-inlet - with clean filter	5 in. Hg (127 mm Hg)							
Maximum restriction @ lift pump-inlet - with dirty filter	9 in. Hg (229 mm Hg)							
Maximum return line restriction - without check valves	20 in. Hg (508 mm Hg)							
Minimum fuel tank vent capability	127 ft ³ /hr (3.81 m ³ /hr)							
Maximum fuel temperature @ lift pump inlet	160 °F (71 °C)							

Starting and electrical system

Minimum recommended battery capacity - cold soak at 0 °F (-18 °C) or above	24V
Engine only - cold cranking amperes	1200 CCA*
Engine only - reserve capacity	640 minutes*

*Based on FM requirement for a minimum of 900 CCA and 430 reserve capacity minutes

Battery cable size - minimum of 2/0 AWG and maximum cable length not to exceed 6 ft. (1.5 m)	24V
Maximum resistance of starting circuit	0.002 Ohms
Typical cranking speed	110 RPM
Alternator (standard), internally regulated	75 amps

Operating conditions

Operating speed in RPM	1470		1760		1900		2100	
Output - BHP (kW)	1017	(759)	1137	(848)	1115	(832)	997	(744)
Ventilation air required - CFM (litre/sec)	2121	(1001)	2860	(1349)	2905	(1371)	3067	(1447)
Exhaust gas flow - CFM (litre/sec)	5722	(2700)	7703	(3635)	7721	(3644)	7751	(3658)
Exhaust gas temperature - °F (°C)	1113	(601)	938	(503)	938	(503)	866	(463)
Heat rejection to coolant - BTU/min. (kW)	24925	(438)	34747	(612)	35098	(617)	37204	(654)
Heat rejection to ambient - BTU/min. (kW)	5283	(93)	6646	(118)	6713	(119)	6406	(113)

Engine performance curve for CFP30E-F20

RPM	lb-ft	N-m
1470	3634	4926
1760	3393	4600
1900	3082	4179
2100	2493	3381

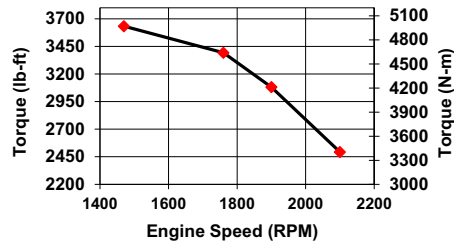

RPM	BHP	kW
1470	1017	758
1760	1137	848
1900	1115	831
2100	997	743

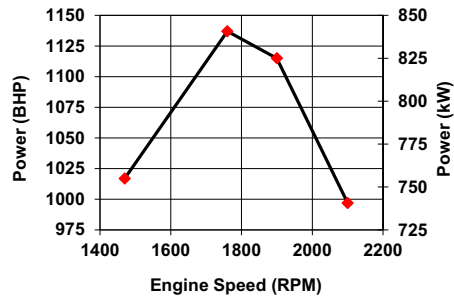

Engine performance curve for CFP30EVS-F20

RPM	lb-ft	N-m
1760	3393	4600
1900	3082	4179
2100	2493	3381

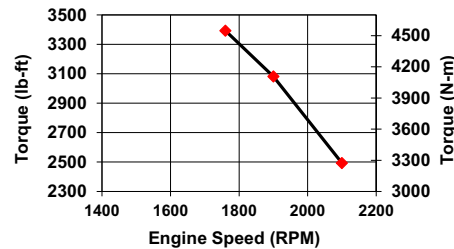

RPM	BHP	kW
1760	1137	848
1900	1115	831
2100	997	743

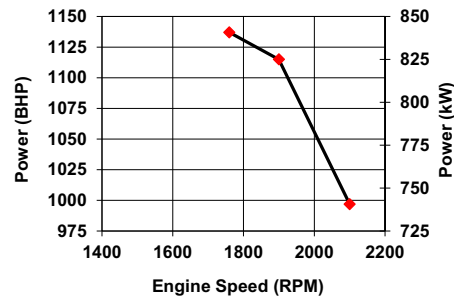

All data is based on the engine operating with a fuel system, water pump, lubricating oil pump, air cleaner, and alternator. The fan, optional equipment, and driven components are not included. Data is based on operation at SAE standard J1349 conditions of 300 ft. (91.4 m) altitude, 29.61 in. (752 mm) Hg dry barometer, and 77 °F (25 °C) intake air temperature, using No.2 diesel fuel only.

Altitude above which output should be limited*:	300 ft. (91.4 m)
Correction factor per 1000 ft. (305 m) above altitude limit:	3%
Temperature above which output should be limited:	77 °F (25 °C)
Correction factor per 10 °F (11 °C) above temperature limit:	1% (2%)

* Above 5,000 feet, contact Cummins for derate information.

Fire pump digital panel (FPDP)



The Cummins FPDP is an integrated microprocessor-based control system that provides full digital technology with enhanced accuracy and built-in redundancy.

Reliable design - Designed and tested with isolated mounting to minimize vibration for longer life and durability, the Cummins FPDP proves reliable in harsh environments.

Advanced control methodology - The Cummins FPDP allows for Input/Output (I/O) expansion and remote monitoring capabilities, as well as automatic Electronic Control Module (ECM) switching for electronic engines.

Certified quality - The Cummins FPDP is UL 1247 Listed and FM 1333 Approved.

Operator panel features

Operator/display panel

- 7" TFT LCD (thin-film-transistor liquid-crystal display) - color, 24-bit, 800x480 (WVGA).
- Auto, manual, start, stop, and fault reset.
- Assembly enclosure that meets NEMA Type 2 and Type 4X design requirements and is water, corrosion, fire, and impact-resistant.

Electronic engine communications - SAE J1939 protocol.

- Comprehensive full-authority engine (FAE) data: oil pressure and temperature; coolant temperature; and intake manifold pressure and temperature.
- Cummins fault code display.
- Sensor failure indication.
- Optional RS-485 serial - Modbus RTU/Modbus TCP/IP.

Variable speed pressure limiting control (VSPLC) capabilities

- VSPLC status indication.
- Pump discharge pressure display.
- Ability to run the engine at fixed speed from the FPDP at start-up for commissioning.

Other control features

- Digital Panel Expansion Module (DPEM) for additional analog/digital inputs and configurable dry relay contact output.
- Ability to idle at start-up for commissioning of electronic engines.
- Idle cool down for electronic engines.

Functional

- Configurable display units for temperature in degrees Fahrenheit or Celsius and pressure in PSI or kPa.
- Manual ECM selector switch on electronic engines.
- Ability to crank the fire pump drive engine from Battery A, Battery B, or both.
- Fixed engine speed adjustments in +/- 10 RPM increments.
- Overspeed shutdown.

Environmental

- Operating temperature: minus 4 to 140 °F (minus 20 to 60 °C).
- Storage temperature: minus 22 to 176 °F (minus 30 to 80 °C).
- Meets CISPR 11 Class B radiated emissions.

Electrical

- 8-30 VDC operating voltage.
- Reverse polarity protected.
- Spring cage terminal block interface.
- Built-in dual micro controllers for increased reliability.

Mechanical

- 1 3/8" pre-cut customer conduit knockout for easy field installation.
- Simplified internal design for efficiency and ease of customer connections.
- 16GA ASTM A366 material - 316 stainless steel optional.
- RAL3001 red powder coat finish.

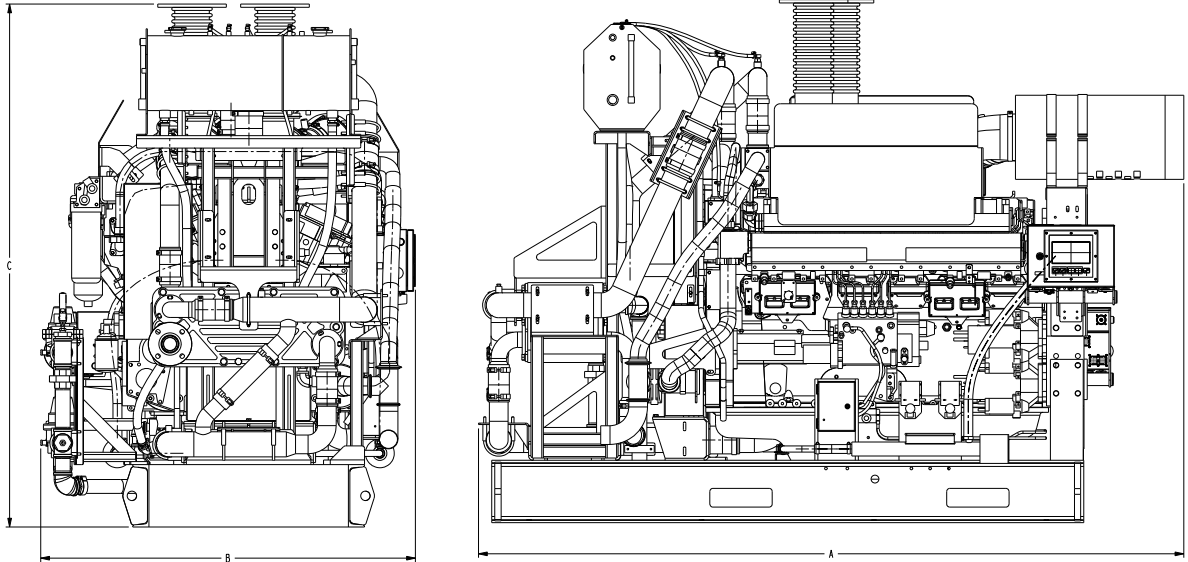

This outline drawing is for reference only.
Do not use for installation design.

	Dim "A" in. (mm)	Dim "B" in. (mm)	Dim "C" in. (mm)
CFP30E	111 (2832)	60 (1524)	84 (2131)

NOTE: Consult drawings or contact the factory for additional information.

NOTE: Specifications are subject to change without notice. Codes or standards compliance may not be available with all model configurations - consult factory for availability.
For more information, contact firepumpsales@cummins.com.



This product has been manufactured under the controls established by a Bureau Veritas Certification approved management system that conforms with ISO 9001:2015.



Cummins Inc.
Box 3005
Columbus, IN 47202-3005
U.S.A.

1-800-CUMMINS™ (1-800-286-6467)
cummins.com

Printed in U.S.A.
©2021 Cummins Inc.